

Flange: **FL9025**
 Gasket: GK9025

Motor:
 Small Block

Suit 38mm Pipes.

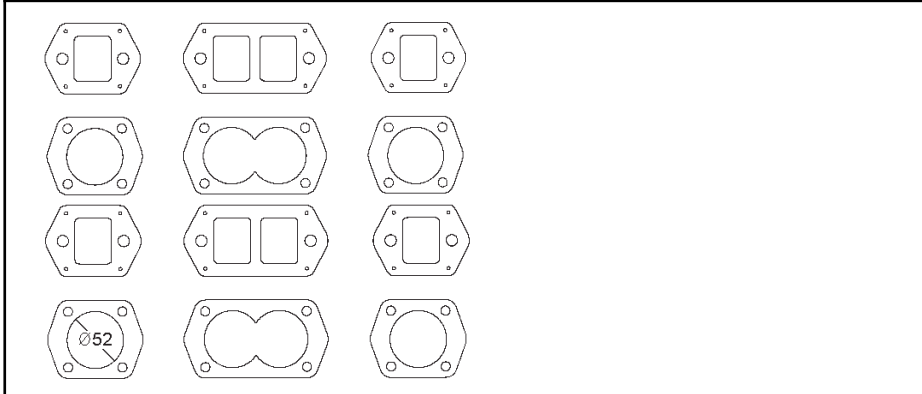

Flange: **FL9026**
 Gasket: GK9026

Motor:
 Small Block

Dual Plates. Suit 51mm Pipes.

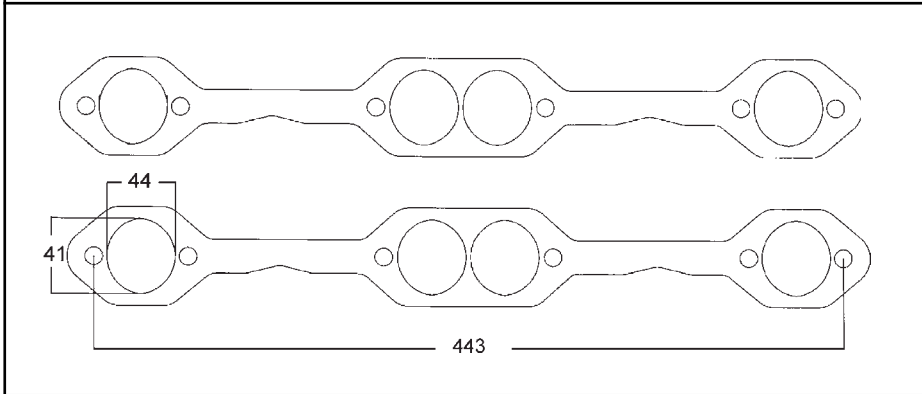

Flange: **FL9027**
 Gasket: GK9027

Motor:
 Small Block

Suit 44mm Pipes. Oval Port.
 Suit 41mm Pipes.
 Can Butt Weld 44OD.

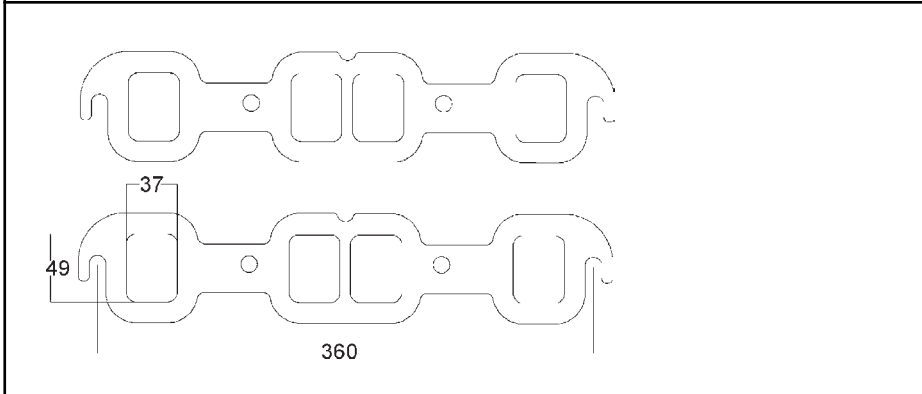

Flange: **FL9204**
 Gasket: GK9204

Motor:
 Pontiac 6000cc
 Small Block

V8 Uneven Ports.

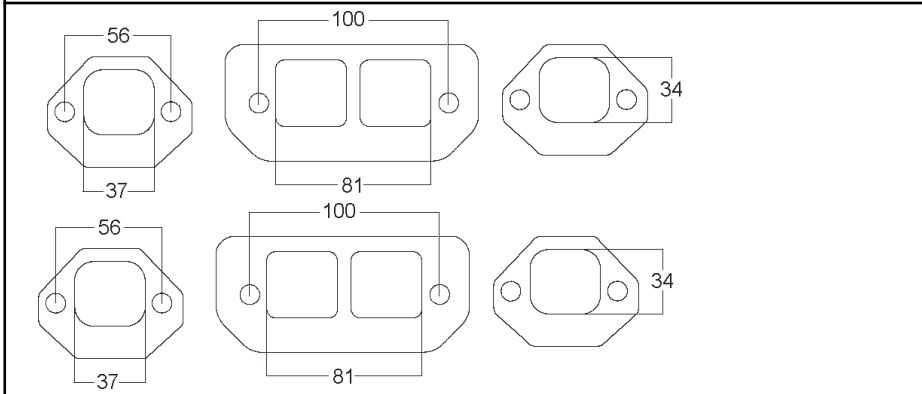

Flange: **FL9226**
 Gasket: GK9025

Motor:
 Small Block

Square Ports.

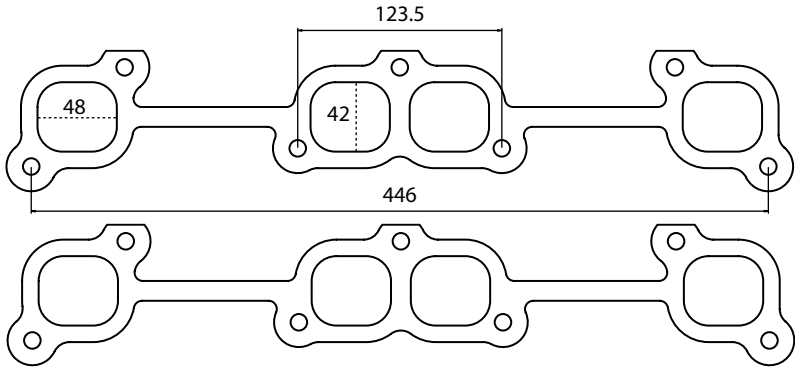
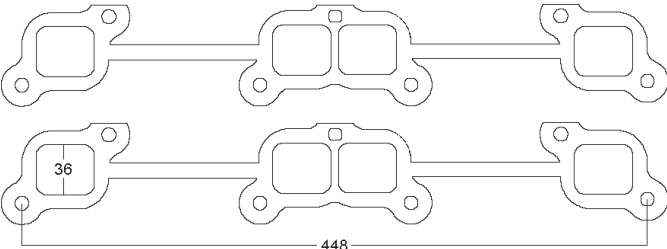
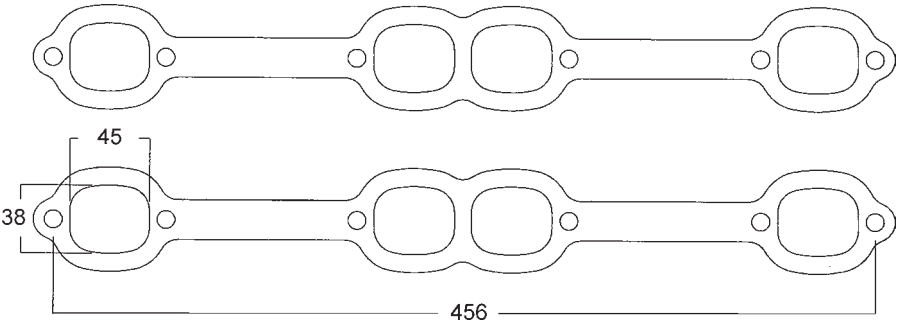
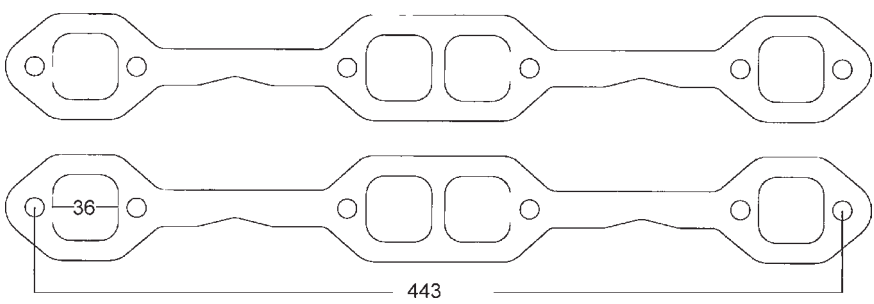
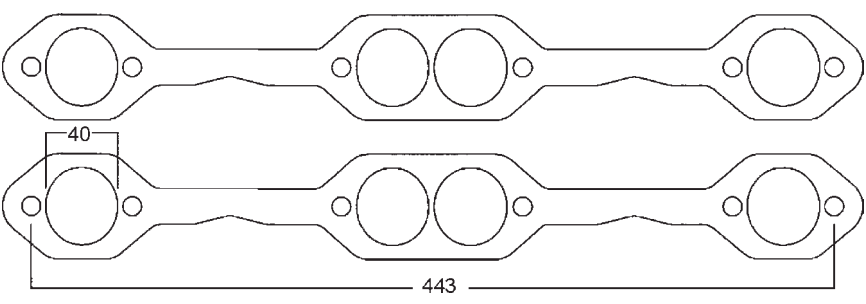
	<p>Flange: FL9142 Gasket: GK9236</p> <p>Motor: Small Block</p> <p>AIR FLOW RESEARCH Heads. V8</p>
	<p>Flange: FL9236 Gasket: GK9236</p> <p>Motor: 350 5735cc OHV 16V Small Block</p> <p>AIR FLOW RESEARCH 23 Degrees. V8 227 Runners.</p>
	<p>Flange: FL9286 Gasket: GK9025</p> <p>Motor: 350ci 5735cc OHV 16V Small Block</p> <p>AIR FLOW RESEARCH V8</p>
	<p>Flange: FL9238 Gasket: GK9238</p> <p>Motor: 350 5735cc OHV 16V Small Block</p> <p>V8 Square Ports.</p>
	<p>Flange: FL9263 Gasket: GK9025</p> <p>Motor: 350 5735 OHV 16V Small Block</p> <p>V8 Suit 41mm Pipes.</p>

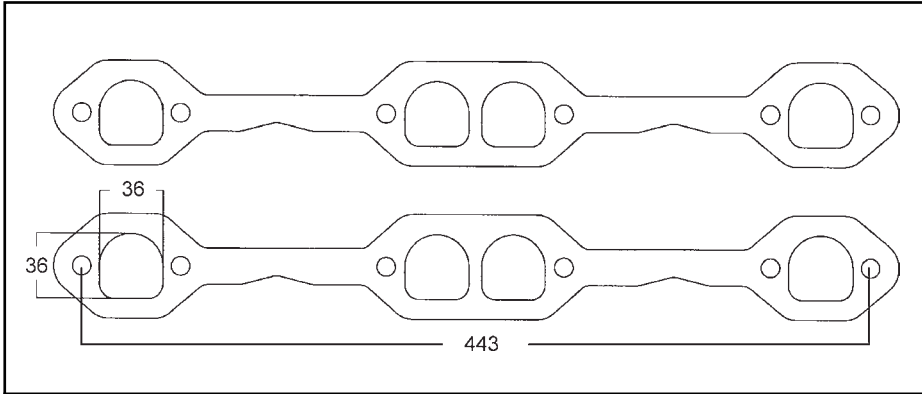

Flange: **FL9283**
 Gasket: GK9025

Motor:
 350 5735 OHV 16V
 Small Block

V8

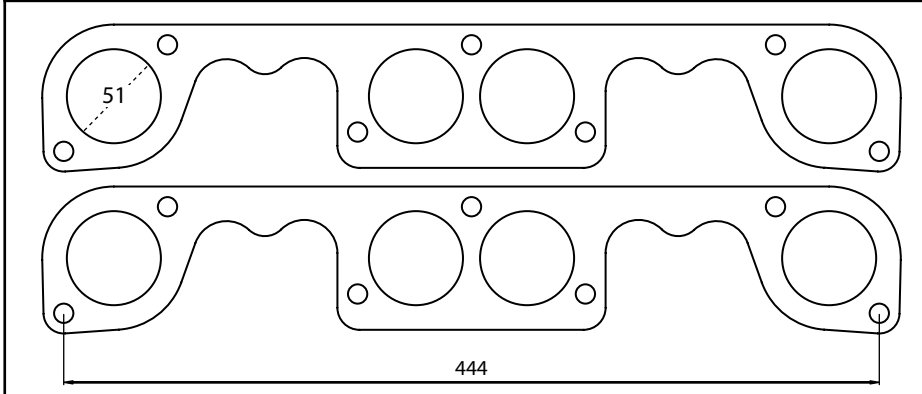

Flange: **FL9387**
 Gasket:

Motor:
 350ci 5735cc OHV 16V
 Small Block

V8

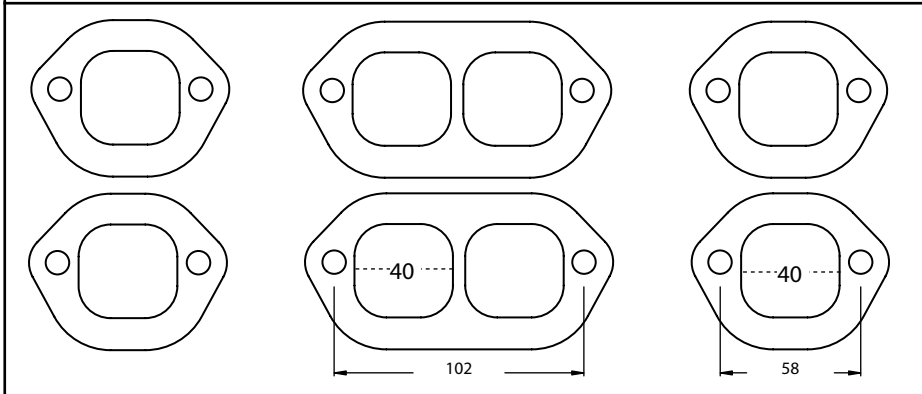

Flange: **FL9405**
 Gasket:

Motor:
 F5000
 Small Block

V8

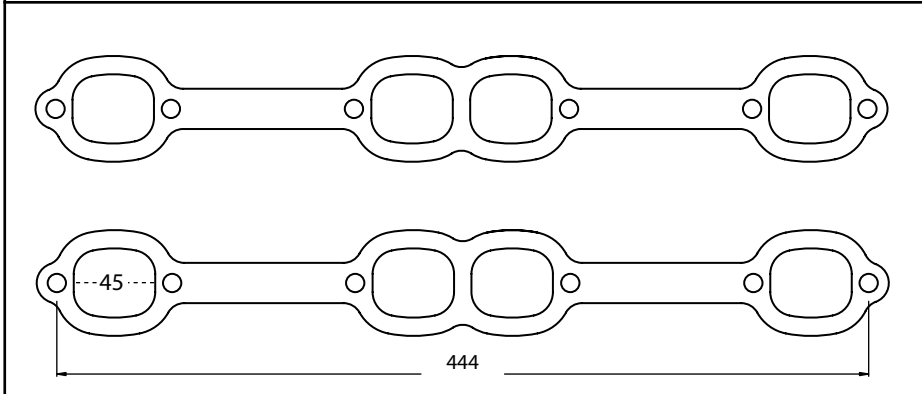

Flange: **FL9419**
 Gasket:

Motor:
 Bow Tie
 Small Block

V8

